

Introduction





This application note reviews the basic operation of the Extrusion functions within Bose® Modeler® software, version 6.6 or newer, and the use of these tools to quickly create complex room models. In addition, this application note covers the use of the Merge Surfaces and Add Doors/Windows functions.

Within this application note the following concepts are discussed:

- Overview of extrusion tools and their function.
- Modeling complex geometries using extrusions
- Adding room features using extrusions
- Detailing room features using the add doors and windows tools
- Modifying the room model using the merge surfaces tool

Extrusion Tools Overview

Modeler software includes five extrusion tools to assist in the creation of room models and complex room features. Found on the Extrusion Toolbar, the extrusion tools include:

Icon	Tool	Description
	Extrude Walls	Creates a complete set of walls, capped by a ceiling plane based on a single floor surface. The extrusion will always be along the Z-axis and to the extent is specified by the user. Typically used to either quickly create a room model, or to create the starting point for room modeling which can be edited to create the final model. Extrude Walls can also be used to extrude "downwards" from the floor surface.
	Extrude Surface	Extrudes a set of surfaces from a reference surface within the room model. The surfaces will terminate at the specified target surface. Typically used to quickly complete a room model based on a set of two reference surfaces.
	Extrude Rectangular Surface	Extrudes a set of walls from a rectangular surface. Typically used to quickly create a room model or a complex room feature.
	Extrude Polygonal Surface	Extrudes a set of walls from a polygonal floor surface. Typically used to quickly create a room model or a complex room feature.
	Extrude Arc	Extrudes an arc or column from a reference surface. Typically used to create a cylinder or column within the room model which is bounded by a floor and ceiling surface.

When using the extrusion tools there are some terms with which you will want to become familiar.

Extent – the endpoint of the extruded surface. Some surfaces are extruded from a selected surface, so one of the Extents is known, while the other must be specified. In cases where two extents must be defined the minimum extent has the lowest elevation in the model, and the maximum has the highest elevation in the model.

Modeler®

Using Extrusion Tools



Termination – determines how the end of the extrusion will be handled. It can be left open, closed, or no action can be specified.

Within Modeler® software extrusions fall into two categories:

An **EXISTING** surface is extruded in the direction of three axes: X, Y, Z or the normal of the surface. A surface normal to a flat surface is a vector which is perpendicular to that surface. In this case, the existing surface remains unchanged. The Extrude Walls and Extrude Surface tool perform this operation.

A **VIRTUAL EXTRUSION SHAPE** is drawn in the room model and extruded in the direction of one of the three main axes: X, Y, Z. The virtual plane disappears once the extrusion is completed, and the newly extruded surfaces terminate at two other existing planes (donor planes).

In other words, the extruded shape is limited by features in the room model that intersect with the extruded shape. The following are several examples of how these tools can be used.

Extrusion Basics

The extrusion tools are intended to help you quickly create room models, and the two tools used most often for this purpose are the Extrude Walls tool and the Extrude Surface tool.

The use of the Extrude Walls tool to create a basic room geometry which can be edited is covered within the Introduction to Modeler training.

The **Extrude Surfaces** tool creates a set of surfaces between two surfaces. Using this tool it is possible to quickly create room models from two wall surfaces.

The following examples illustrate of how a model can be quickly created using the Extrude Surface tool:

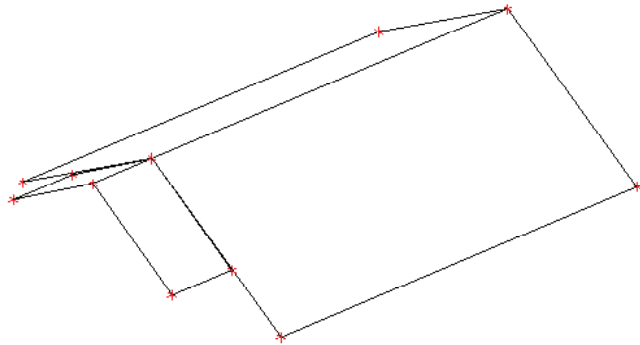
<p>Step One: Model the Ceiling. In this model the ceiling describes the overall shape of the room, and can be quickly modeled.</p>	
---	--

Modeler®

Using Extrusion Tools

Step Two: Using the ceiling shape as a template to model the floor using the Polygonal Surface tool.

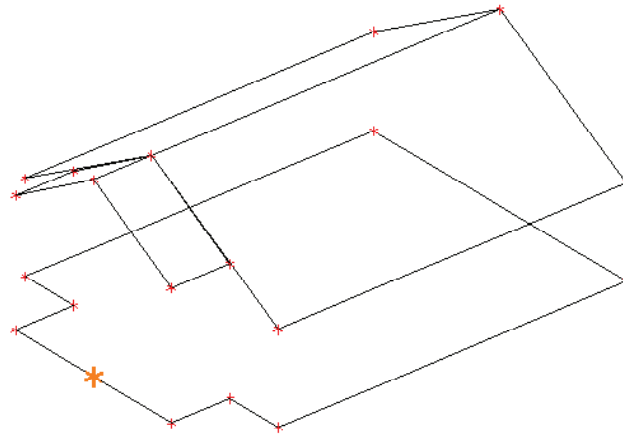

Step Three: You are now ready to extrude the remaining surfaces. After selecting the floor, Select the Extrude Surface tool. 

The floor is the one known extent, and we must specify the Ceiling will be the other extent for all extruded surfaces.

In this model since we already have a ceiling we will define the termination as None.

Define the surface attributes and click OK.

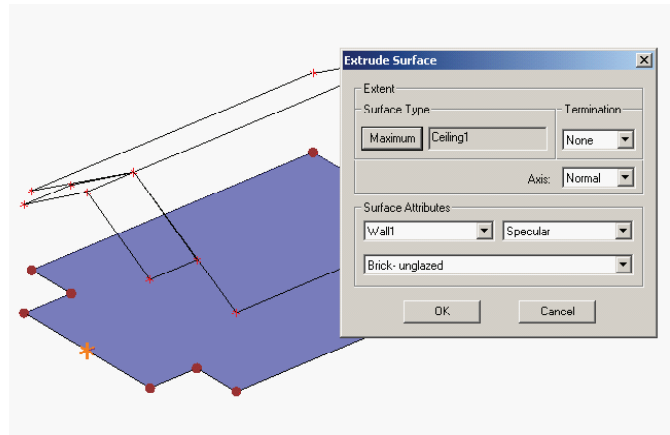

Step Four: The basic model is created and is ready for editing, or a basic design can be implemented.

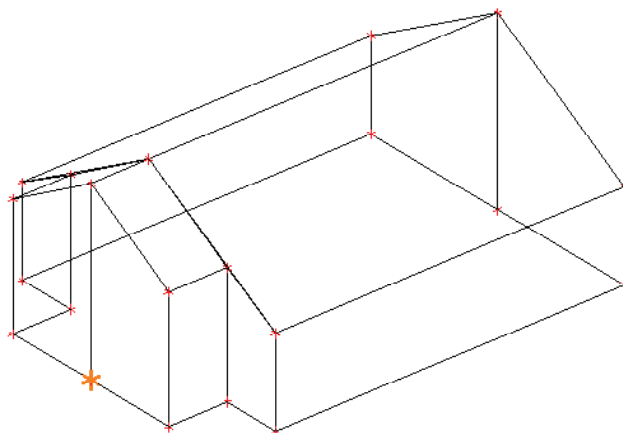

Modeler®

Using Extrusion Tools



In this second example we will create an auditorium room model, but we will only model a single surface.

Step One: In this example the side wall of the auditorium can be used to describe the articulated ceiling and raked seating area. In this case we will draw the shape of the side wall using the draw Polygon tool in plan view, and then rotate the wall so that it lies in the X,Z plane.

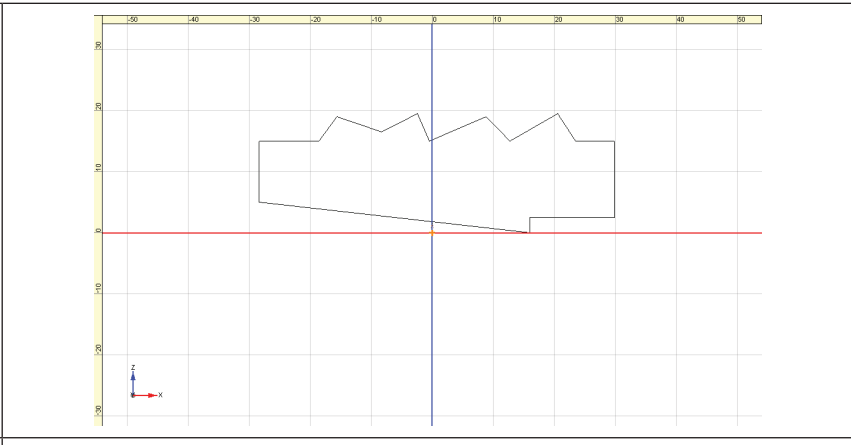

Step Two: Mirror the surface. You now have two side walls.

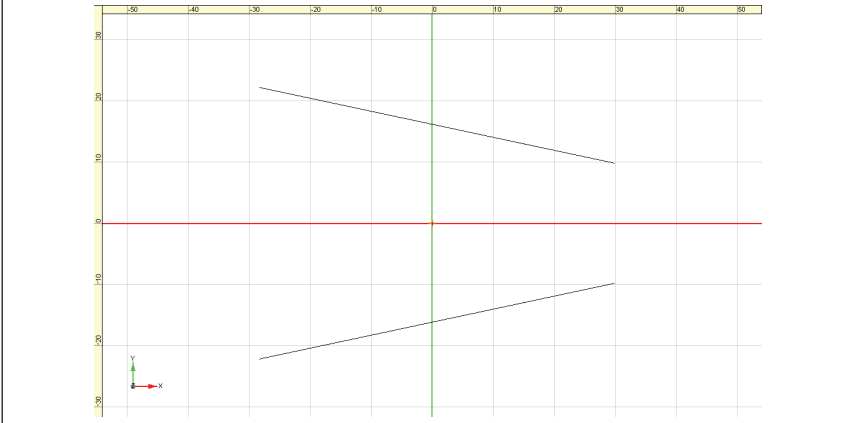

Step Three: Use the Extrude Surface tool to create the complete room model. Note that when extruding this surface we must extrude it along the Y (red) axis.

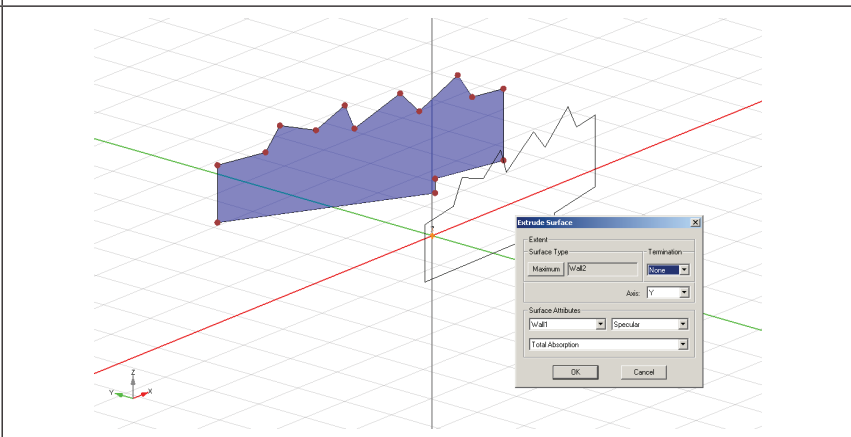

Step Four: When a surface is extruded the new surfaces are created as a group.

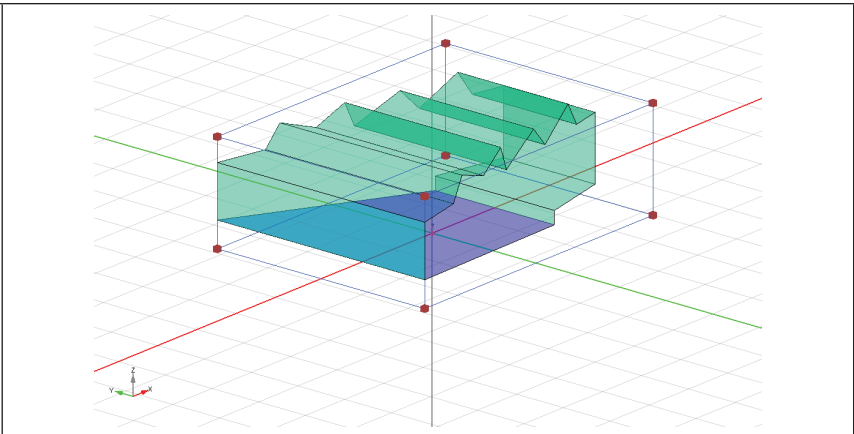

Step Six: Now that all of the surfaces of the room model exist we will need to manually edit their individual surface properties. This is accomplished using the Surfaces Tab, and stepping through each surface individually.

Note that the selected surface is highlighted in blue.

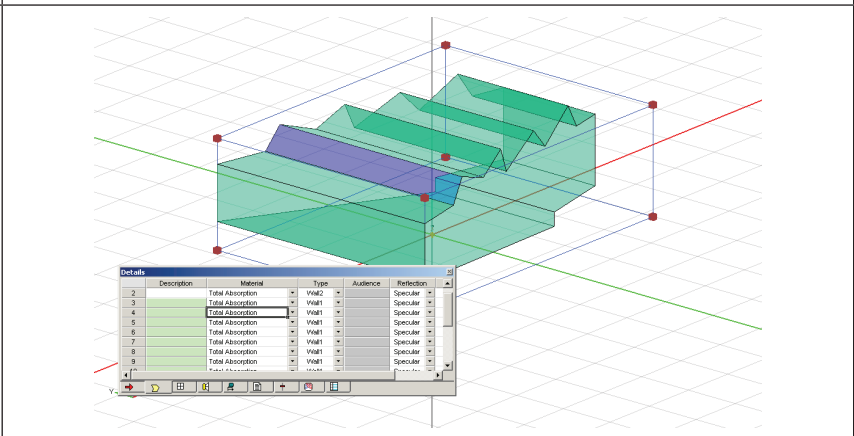

The **Extrude Rectangular Surface**, **Extrude Polygonal Surface** and **Extrude Arc** tools create a set of surfaces from a polygonal or rectangular or arc shape. The new surfaces are extruded between two existing room model surfaces.

In the first example we used the Extrude Surface tool to extrude the walls for the room model. In this example we will use the Extrude Polygon tool to add an interior room feature.

Step One: Define the shape of the new extrusion using the polygonal or rectangular extrusion tool.

Define the termination for the extents of the new extrusion. In this case the bottom, (Minimum,) extent will be open, and the top, (Maximum,) extent will not be terminated.

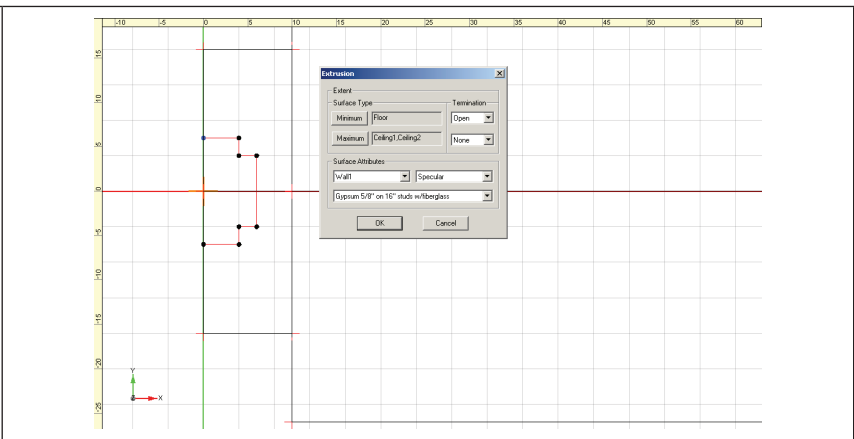

Modeler®

Using Extrusion Tools

Step Two: View the results of the newly extruded surfaces.

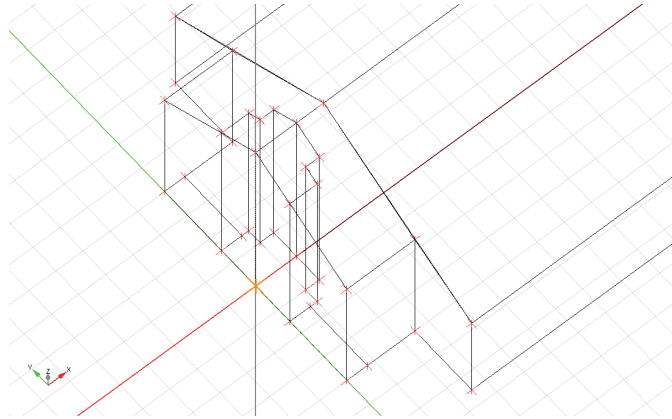

When a new extrusion is created using an open termination, Modeler® software will modify adjacent surfaces such that they properly intersect the newly extruded surfaces, but do not create any bent planes. In some cases this results in a large number of surfaces being created.

The **Merge Surfaces** is used to clean up the room model once an extrusion with an open termination is created and after a model or individual surfaces are mirrored. Let's look at how we can use the Merge Surfaces tool to reduce the number of surfaces used in this room model.

Step One: Select two or more adjacent surfaces which are coplanar.

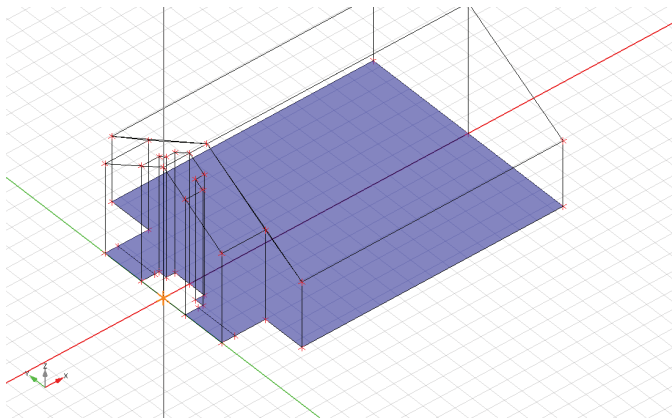

Step Two: Select the Merge Surfaces  tool and the two surfaces are now merged into a single surface.

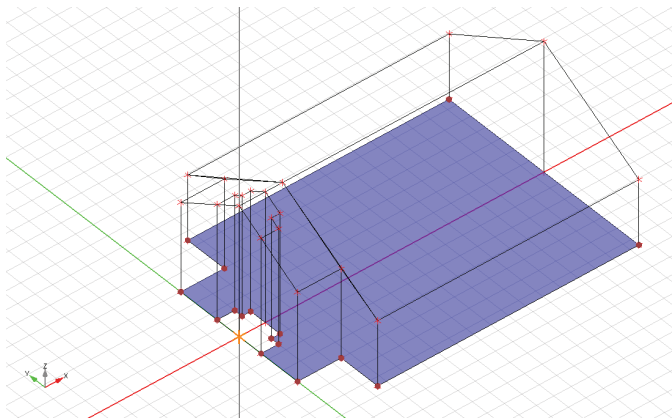

Modeler®

Using Extrusion Tools



Step Three: Repeat this process for all the coplanar surfaces in the room model.

Note: Surfaces containing holes are filled (holes eliminated) when they are included in a Merge Surfaces selection set.

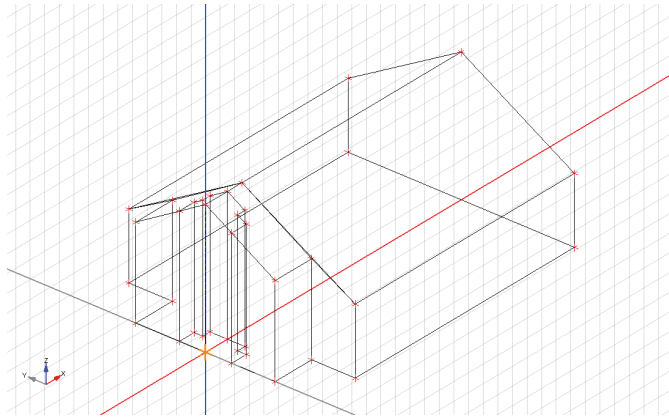

Room Model Example



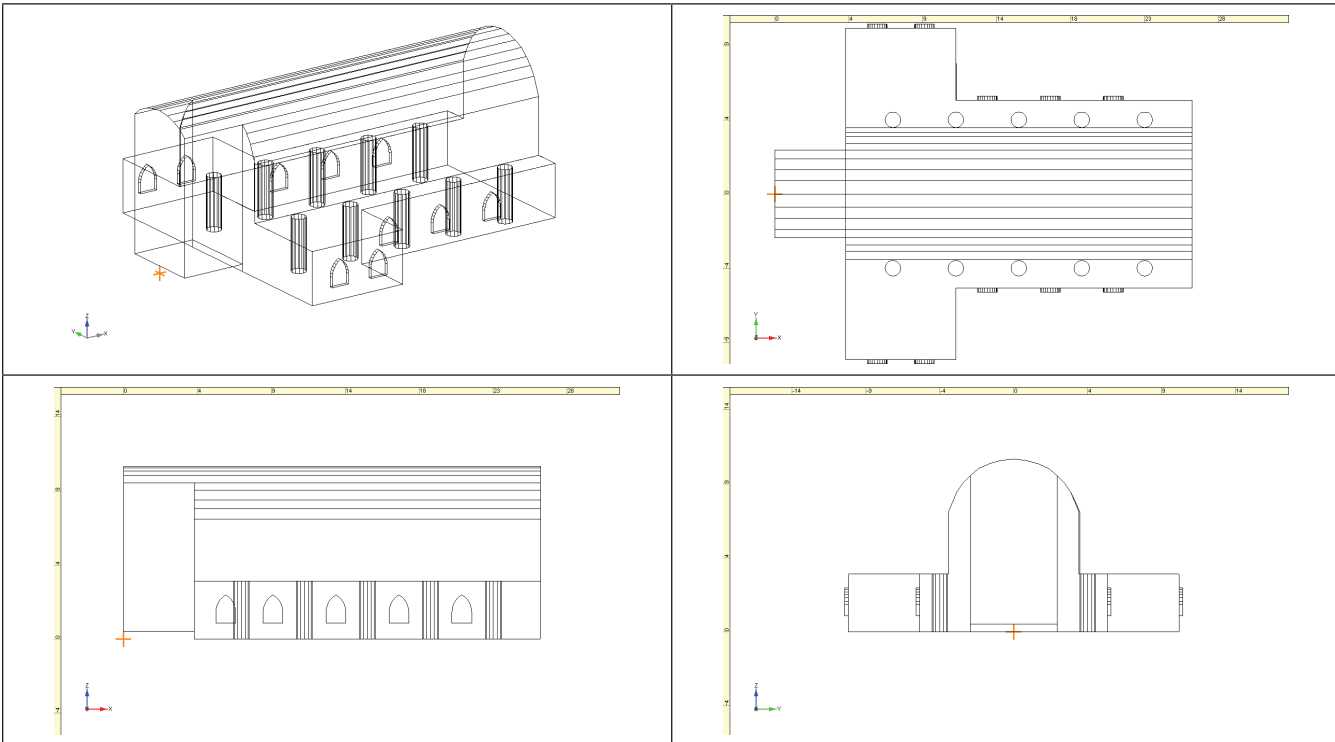

The tools provided within the Modeler® software can greatly simplify the process of room model creation. In this example we will create a room model using a minimum of drawn surfaces, and will primarily rely upon using the extrusion tools to achieve the overall room geometry and unique room features. The model we will create is a basic cathedral, and the final room model will look like this:

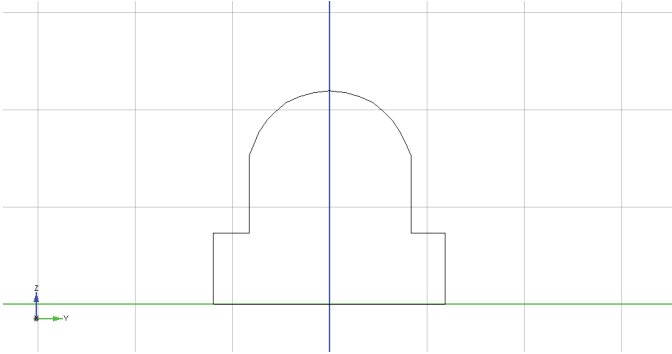

Modeler®

Using Extrusion Tools

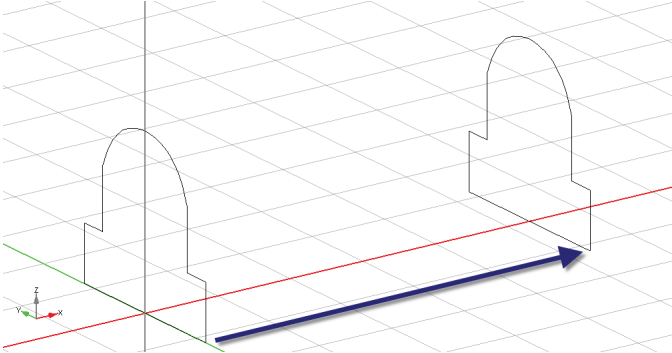
Now let's look at the steps that were used to create this room model.

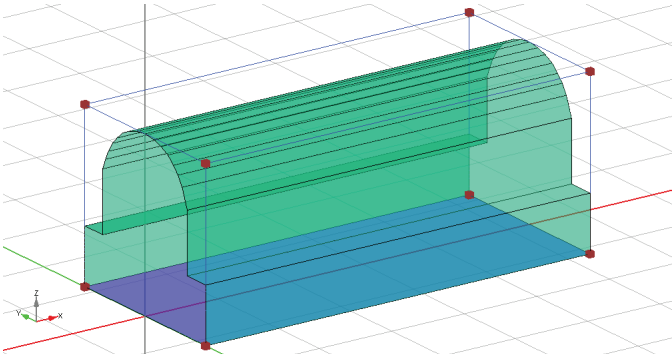
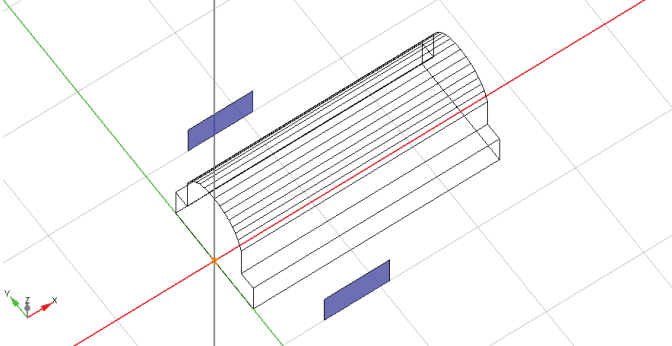
<p>Step One: We will start by modeling the front wall using the Polygonal Surface tool. This surface is constructed in the Elevation view to eliminate unnecessary surface rotations. </p>	
<p>Step Two: In order to extrude this surface we need to create a target surface – the rear wall. This is accomplished by copying the front wall and pasting a duplicate surface into the model. Unlock the model  and move the newly pasted surface into position.</p>	
<p>Step Three: Use the Extrude Surface tool  to create the basic shape of the nave.</p> <p>The newly extruded surfaces are created as a group. At this point is recommended that you modify their Surface Types, Materials, and Reflection properties.</p>	
<p>Step Four: Now we will add the transepts. To do this we will create the end wall of the transept on either side of the nave.</p>	

Modeler®

Using Extrusion Tools

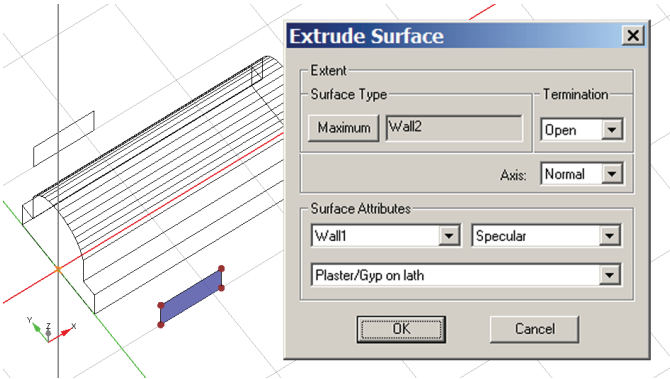
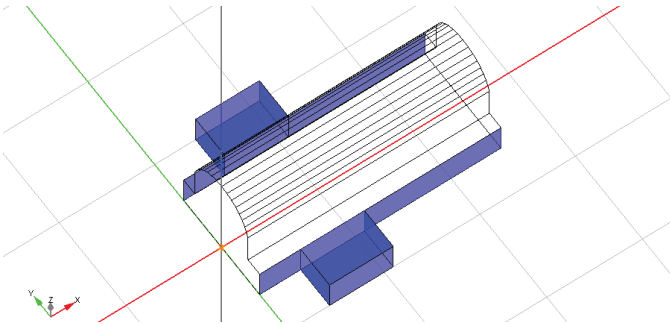
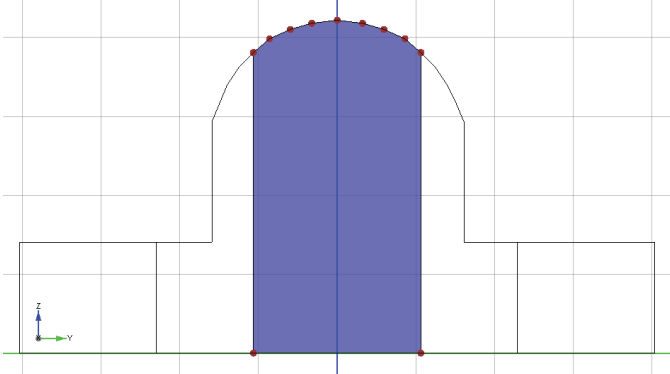
<p>Step Five: The transept end walls will be extruded to the side wall of the nave. In this case, the termination is set to Open because the transept is open to the room.</p> <p>This process is repeated for the opposite side.</p>	
<p>The completed extrusion action yields several new surfaces shown here as highlighted objects.</p>	
<p>Step Six: We now have the basic shape of our room model, and we can use the editing tools to form the apse.</p> <p>To accomplish this we will adjust the vertices of the front wall for a narrower width leaving gaps to fill using the Insert Face tool.</p>	

Modeler®

Using Extrusion Tools

Highlighted objects illustrate new surfaces to add to fill in the gaps around the newly created apse using the Insert Face tool or by adding vertices to existing surfaces and dragging them to their new destinations.

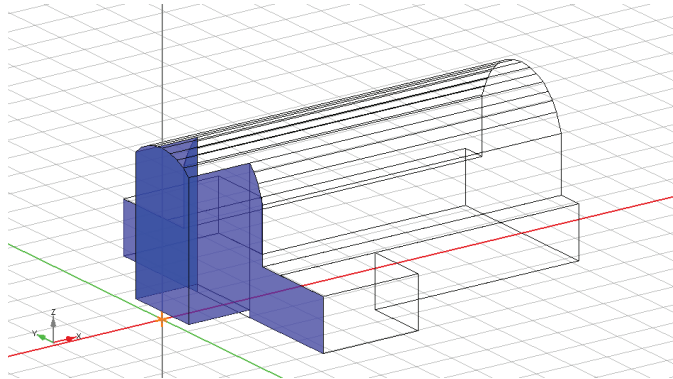

Step Seven: Our model is now nearly complete and we are ready to add some of the interior details.

Using the Extrude Arc tool  we will add the columns to the room model. We choose an Open termination to avoid adding enclosed spaces to the room model. Repeat this process for all remaining columns.

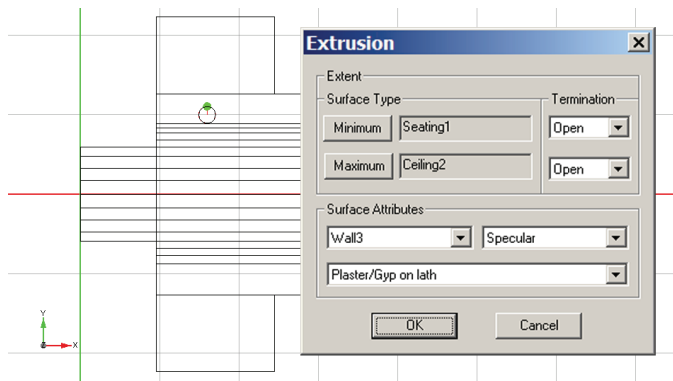

Using the Add Doors/Windows tool  we will insert windows along the nave and transept walls.

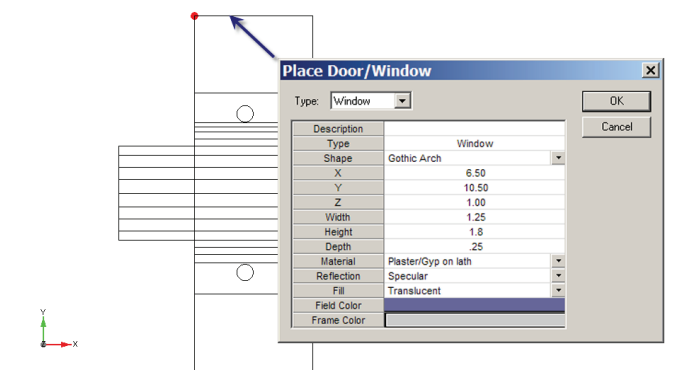

After adding all remaining windows, the model looks like this.

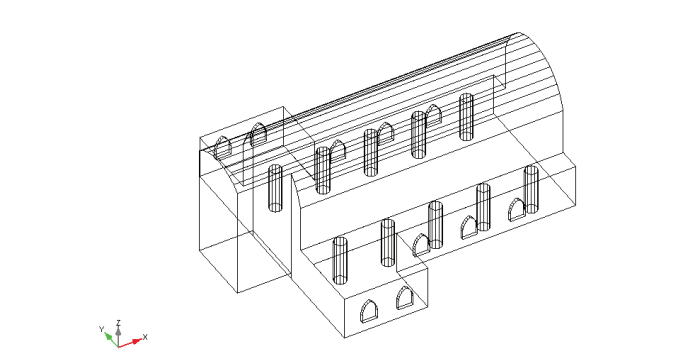

Modeler®

Using Extrusion Tools



Step Eight: It is possible to simplify the view of this model using the Merge Surfaces tool to merge the nave and transept ceilings into a single plane.

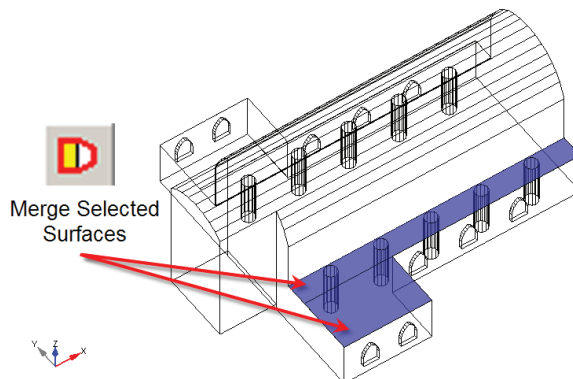

Step Nine: Additional room details such as seating areas and doors can also be added at this time as indicated by highlighted objects. We now have a complete model ready for a sound system design.

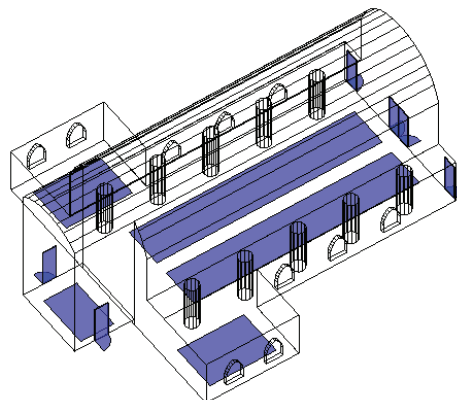

Summary

The Extrusion Tools within Modeler® software can greatly simplify the process of model creation and adding detailed room features to the model.

