



Technical information

Frequency range

55Hz to 16kHz \pm 3dB

Sensitivity¹

91dB-SPL @1W, 1m (pink noise)

Maximum acoustic output²

114dB-SPL @1m (pink noise)

116dB-SPL @1m (IEC3 noise)

Dispersion (–6dB point, average, 1-4kHz)

Horizontal 120 °, Vertical 100 °

Long-term power handling⁴

240W continuous

Impedance

8 Ω nominal

Mechanical specifications

Dimensions: (33 cmH x 52 cmW x 32 cmD)

Weight: 14 kg

Connectors: two (2) parallel-wired

NL4 connectors

Enclosure construction: mica-reinforced polyethylene copolymer structural foam

General description

The BOSE® 802® series III loudspeaker is a 240- Watt, full-range loudspeaker designed for permanent installations and portable use in indoor and outdoor commercial applications. As a new addition to the Bose line of Installed Anywhere™ loudspeakers, it meets our strictest standards for outdoor use.

The Bose 802 series III loudspeaker offers the following features:

- > Wide-range reproduction over a broad dispersion area
- > A rugged, portable enclosure with metal grille and protective cover with carrying handle
- > Low profile, aesthetic styling
- > Weather-resistant design to ensure reliable performance indoors and outdoors
- > A full complement of brackets and stands available for a variety of product uses

Each 802 Series III loudspeaker uses eight 11.34cm full-range drivers mounted insymme tric vertical pairs on a faceted Articulated Array® baffle assembly. The drivers feature low-impedance, edge-wound ferrite V ceramic magnets, and molded polyester frames. Their advanced cone and motor system give them high linear excursion capability and power output. Environmental durability is built into soft parts – cone, surround and spider – and coated on to the hard parts of the driver. These materials optimize the Installed Anywhere – performance of the loudspeaker.

Bose 802 series III loudspeakers are used in combination with the Panaray system controller or the Bose 1600 or 1800 amplifiers with the 802 plug-in EQ card for active equalisation of the system.

The Panaray controller assures smooth, accurate spectral response across the entire operating range of the 802 series III loudspeaker. Using a controller or EQ card also allows for crossover of the 802-III loudspeaker with a Bose bass loudspeaker.ies III loudspeaker. Using a controller or EQ card also allows for crossover of the 802-III loudspeaker with a Bose bass loudspeaker.

- 1 Full bandwidth pink noise is applied to the 802-III and amplified to a level at the loudspeaker terminals corresponding to 1 Watt as referenced to the nominal impedance.The average sound pressure level (dB-SPL) is measured at 1 metre from the speaker in an anechoic environment.
- 2 Full bandwidth pink noise is applied to the 802-III and amplified to a level at the loudspeaker terminals corresponding to the long-term rated power handling of the speaker.The average sound pressure level (dB-SPL) is measured at 1 metre from the speaker in an anechoic environment.
- 3 Full bandwidth pink noise,meeting International Electrotechnical Commission (IEC)Standard. #268-5,with a spectrum corresponding to average program material.
- 4 Full bandwidth noise,meeting the IEC Standard #268-5 is applied to the 802-III and amplified to a level at the loudspeaker terminals corresponding to the power handling of the loudspeaker.The loudspeaker must show no visible damage or measurable loss of performance after 100 hours of continuous testing.

Installation

Installation and use instructions are included with the loudspeaker. The 802® series III loudspeakers are designed to be wall or ceiling mounted, or mounted on stands for portable use.

The following versatile accessories are available from Bose®:

- > WB1A 802 wall mount bracket
- > WB6 802 swing bracket
- > WBP8 802 wall mount bracket (0-45 ° pitch, ± 40 ° yaw)
- > SB8 802 single fly bracket (0-45 ° pitch)
- > SB82 802 stacked pair fly bracket (0-45 ° pitch)
- > ES-10 speaker stand with mounting adapter and optional carry bag

Loudspeaker configuration

The Bose 802 series III loudspeaker can be used with the Bose 1600 and 1800 amplifiers. It is also compatible with industry standard amplifiers rated for 4-8 Ω loads.

The 802-III speaker is packaged one per carton.

Engineers’ and architects’ specifications

The loudspeaker shall be a multiple driver, full-range system with matched active equalisation as follows:

The transducer complement shall consist of eight (8) full-range environmental drivers of 11.4 cm diameter, mounted symmetrically in vertical pairs on a faceted, removable baffle assembly. Each driver shall have a rated impedance of 1 Ω and shall be wired in series, resulting in a composite nominal impedance of 8 Ω.

The loudspeaker system sensitivity shall be 99dB-SPL in the 300Hz to 3kHz range and 91dB-SPL in the 50Hz to 16kHz range with both measurements referenced to a 1 Watt (2.83V) pink noise input at 1 metre. The nominal horizontal beamwidth shall be 120 degrees, and the nominal vertical beamwidth shall be 100 degrees.

The power handling capacity of the loud - speaker shall be 240 Watts continuous pink noise, band-limited from 50Hz to 16kHz. The loudspeaker shall be provided with a ducted vent system, tuned at 55Hz.

The input connectors of the 802® series III loudspeaker shall consist of two parallel Speakon® NL4 receptacles. The enclosure of the 802 series III loud - speaker shall be composed of micareinforced polyethylene copolymer structural foam.

System configurations

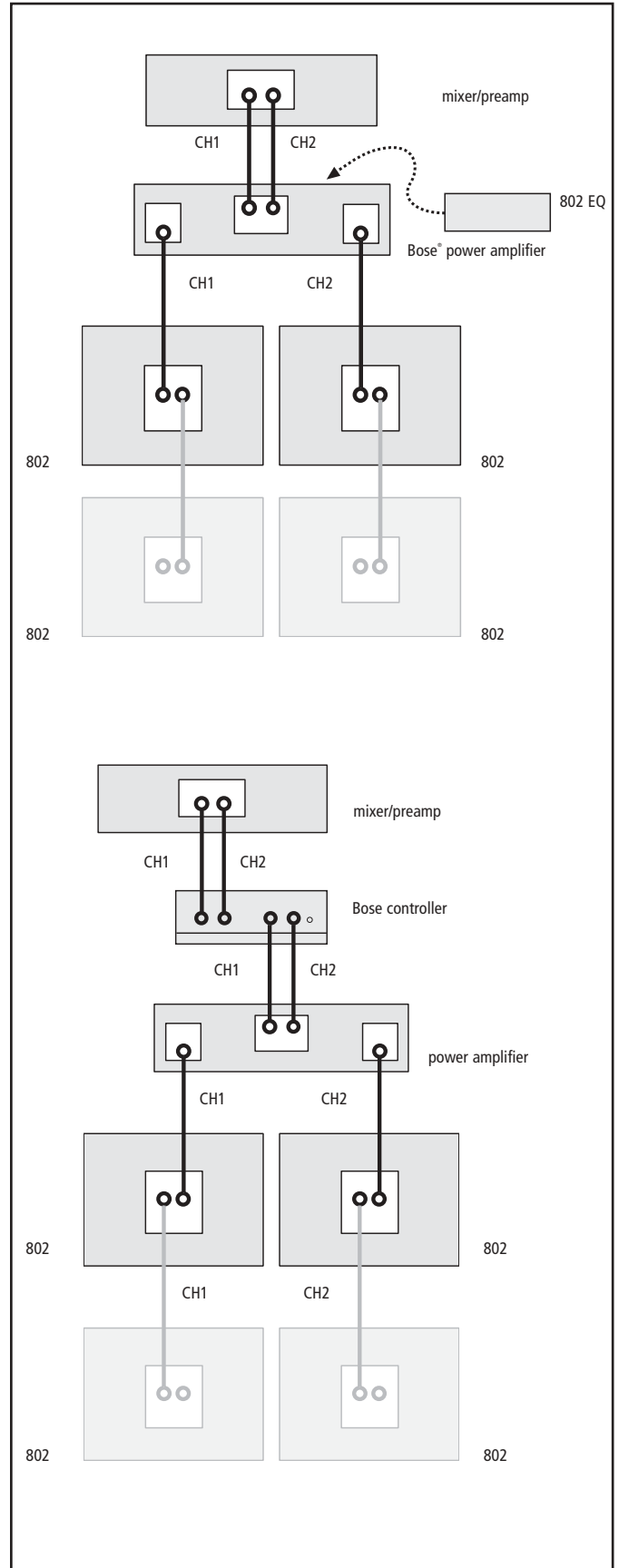

Speakers views

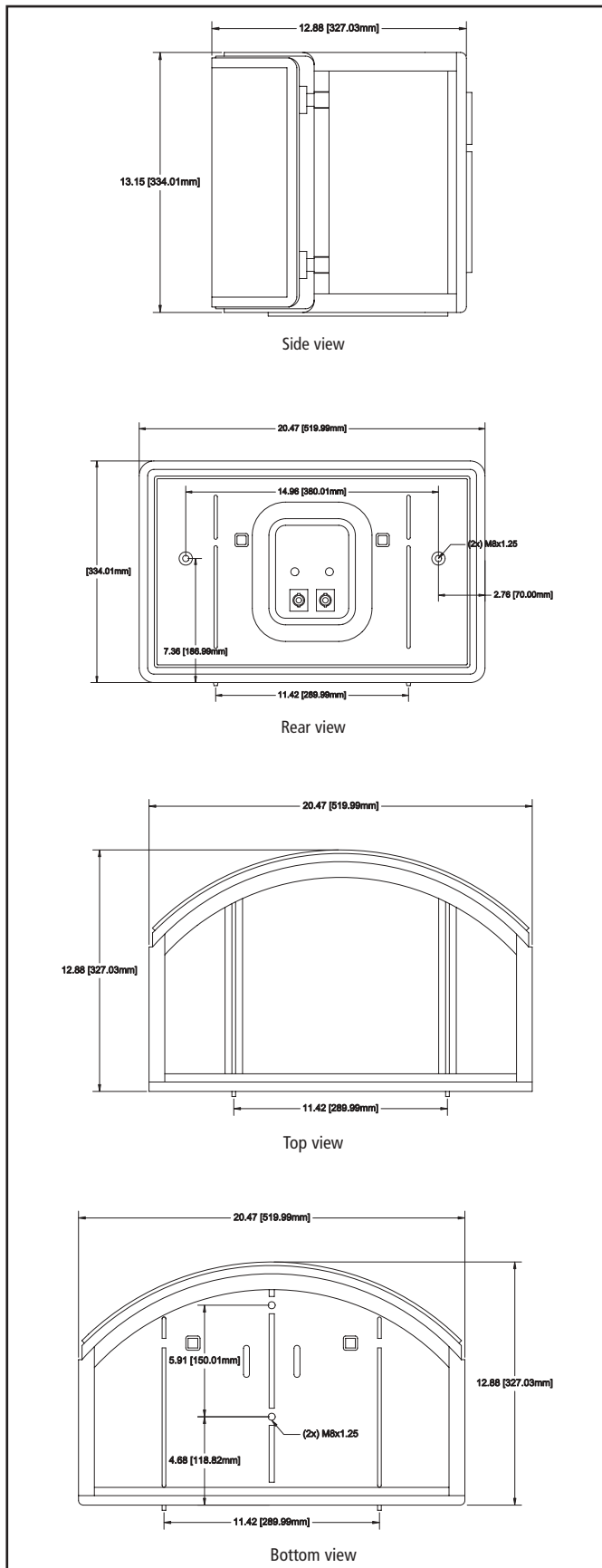

Its outer dimensions shall be 13"H x 20.5" W x 12.5"D (33 cmH x 52 cmW x 32 cmD); its weight shall be 31 lb (14 kg). The loudspeaker shall be the Bose® 802 Series III loudspeaker system. The loudspeaker system shall be used with a Panaray system digital controller, to be connected before the input(s) of the system power amplifier(s), or with an 802 EQ card, to be installed in a Bose 1600 or 1800 amplifier.

The fixed, 2-channel systems controller shall provide active electronic equalisation and crossover functions.

Safety and regulatory compliance

All versions of the Bose 802-III loudspeakers comply with ANSI/EIA 636, recommended loudspeaker safety practices and EMC directive 89/336/EEC and article 10 (1) of the directive in compliance with EN50081-1, EN50082-1, as signified by the CE mark.

Warranty information

All versions of the Bose 802-III loudspeaker are covered by a 5-year, transferable limited warranty.

